

# Model: ZP295KCE-TWD

## Data

---

**Type: Hermetic scroll compressors**

**Producer: Copeland**

**Series: ZP**

## Model: ZP295KCE-TWD

### Technical data

Displacement [m <sup>3</sup> /h]:	46,7
Sound power [dBA]:	85
Sound pressure level [dB]:	74
Net Weight [kg]:	160,0
Gross Weight [kg]:	188
Oil charge [dm <sup>3</sup> ]:	6,8
Maximum high pressure [bar]:	45
Maximum standstill pressure [bar]:	29,5
Minimal lowside temperature [°C]:	-35
Maximum lowside temperature [°C]:	50
PED category:	2

### Electrical data

Power supply [V/~/Hz]:	380-420V/3/50Hz
Locked rotor current [A]:	272,0
Max. operating current [A]:	48,5
Winding resistance [Ω]:	0,5

### Connections

	<u>inches</u>
Suction connection with supplied sleeve:	1 5/8"
Discharge connection with supplied sleeve:	1 3/8"

# Model: ZP295KCE-TWD

## Capacity

R410A

### Cooling capacity [kW]

$t_c \setminus t_e$	-20	-15	-10	-5	0	5	10	15
25	33.47	41.02	49.89	60.23	72.19	85.91	101.55	119.25
30	31.45	38.76	47.31	57.25	68.74	81.92	96.94	113.94
35	29.47	36.48	44.66	54.17	65.14	77.73	92.08	108.35
40	27.47	34.15	41.92	50.93	61.34	73.30	86.94	102.42
45	-	31.72	39.03	47.52	57.32	68.59	81.47	96.13
50	-	-	35.97	43.87	53.02	63.56	75.65	89.42
55	-	-	-	39.96	48.41	58.18	69.41	82.26
60	-	-	-	-	43.45	52.40	62.74	74.62
65	-	-	-	-	38.10	46.18	55.58	66.45

### Power input [kW]

$t_c \setminus t_e$	-20	-15	-10	-5	0	5	10	15
25	11.52	11.68	11.86	12.05	12.26	12.51	12.81	13.17
30	12.72	12.88	13.04	13.22	13.40	13.62	13.88	14.20
35	14.07	14.24	14.39	14.55	14.72	14.91	15.13	15.40
40	15.60	15.77	15.93	16.07	16.22	16.39	16.58	16.81
45	-	17.51	17.67	17.80	17.94	18.08	18.25	18.44
50	-	-	19.64	19.77	19.89	20.02	20.15	20.32
55	-	-	-	21.99	22.10	22.21	22.33	22.46
60	-	-	-	-	24.59	24.69	24.78	24.89
65	-	-	-	-	27.38	27.47	27.55	27.63

# Model: ZP295KCE-TWD

## Capacity

### Current [A]

<b>t<sub>c</sub> \ t<sub>e</sub></b>	<b>-20</b>	<b>-15</b>	<b>-10</b>	<b>-5</b>	<b>0</b>	<b>5</b>	<b>10</b>	<b>15</b>
<b>25</b>	24.87	25.02	25.17	25.34	25.54	25.79	26.09	26.48
<b>30</b>	26.13	26.31	26.47	26.65	26.84	27.07	27.35	27.69
<b>35</b>	27.59	27.79	27.97	28.14	28.33	28.54	28.80	29.11
<b>40</b>	29.29	29.51	29.71	29.89	30.07	30.27	30.50	30.77
<b>45</b>	-	31.54	31.75	31.94	32.11	32.29	32.49	32.73
<b>50</b>	-	-	34.15	34.34	34.51	34.67	34.84	35.04
<b>55</b>	-	-	-	37.14	37.30	37.45	37.60	37.76
<b>60</b>	-	-	-	-	40.55	40.68	40.81	40.93
<b>65</b>	-	-	-	-	44.31	44.43	44.52	44.61

### Mass flow [kg/h]

<b>t<sub>c</sub> \ t<sub>e</sub></b>	<b>-20</b>	<b>-15</b>	<b>-10</b>	<b>-5</b>	<b>0</b>	<b>5</b>	<b>10</b>	<b>15</b>
<b>25</b>	651.94	794.13	956.67	1 142.58	1 354.91	1 596.69	1 870.95	2 180.73
<b>30</b>	647.67	789.81	952.40	1 138.48	1 351.08	1 593.24	1 867.99	2 178.36
<b>35</b>	640.64	782.49	944.89	1 130.89	1 343.53	1 585.82	1 860.82	2 171.55
<b>40</b>	631.24	772.56	934.54	1 120.22	1 332.64	1 574.84	1 849.84	2 160.68
<b>45</b>	-	760.43	921.74	1 106.87	1 318.84	1 560.69	1 835.46	2 146.18
<b>50</b>	-	-	906.91	1 091.24	1 302.52	1 543.79	1 818.09	2 128.44
<b>55</b>	-	-	-	1 073.74	1 284.09	1 524.54	1 798.12	2 107.86
<b>60</b>	-	-	-	-	1 263.96	1 503.34	1 775.96	2 084.86
<b>65</b>	-	-	-	-	1 242.51	1 480.59	1 752.02	2 059.83

# Model: ZP295KCE-TWD

Capacity

## C.O.P. [W/W]

$t_c \setminus t_e$	-20	-15	-10	-5	0	5	10	15
25	2.91	3.51	4.21	5.00	5.89	6.87	7.93	9.06
30	2.47	3.01	3.63	4.33	5.13	6.01	6.98	8.03
35	2.09	2.56	3.10	3.72	4.43	5.21	6.08	7.03
40	1.76	2.16	2.63	3.17	3.78	4.47	5.24	6.09
45	-	1.81	2.21	2.67	3.20	3.79	4.47	5.21
50	-	-	1.83	2.22	2.67	3.18	3.75	4.40
55	-	-	-	1.82	2.19	2.62	3.11	3.66
60	-	-	-	-	1.77	2.12	2.53	3.00
65	-	-	-	-	1.39	1.68	2.02	2.40

## Application range

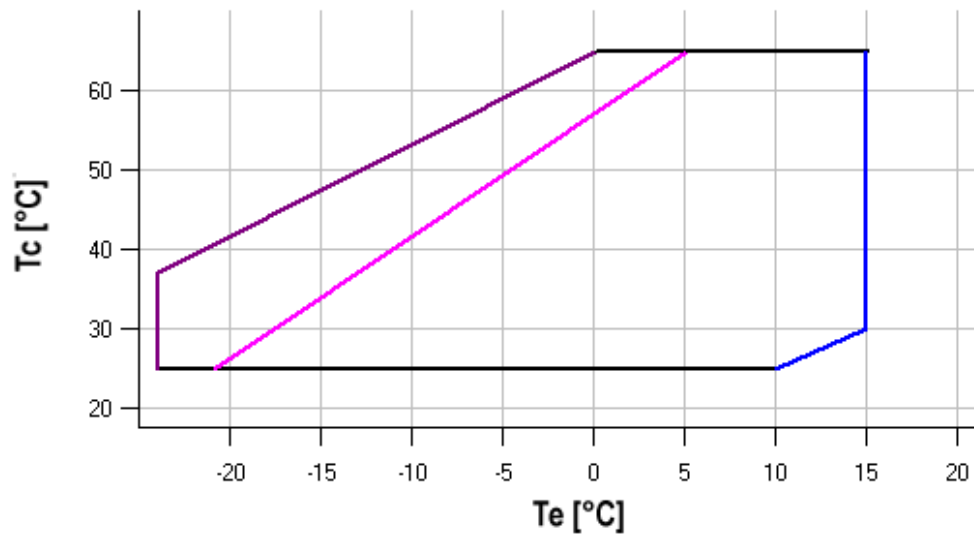

- Maximum evaporating temperature
- 25°C suction gas temperature
- 10K gas overheat

Operating conditions: 10K suction superheat, 0K subcooling

$t_c$  - Condensing temperature [°C]

$t_e$  - Evaporating temperature [°C]

# Model: ZP295KCE-TWD

## Dimensions

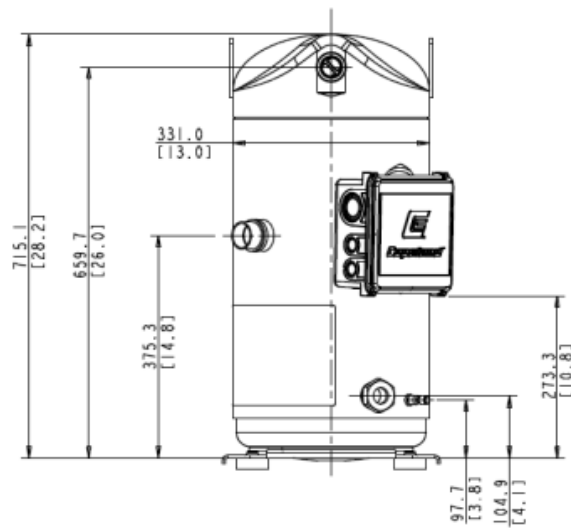
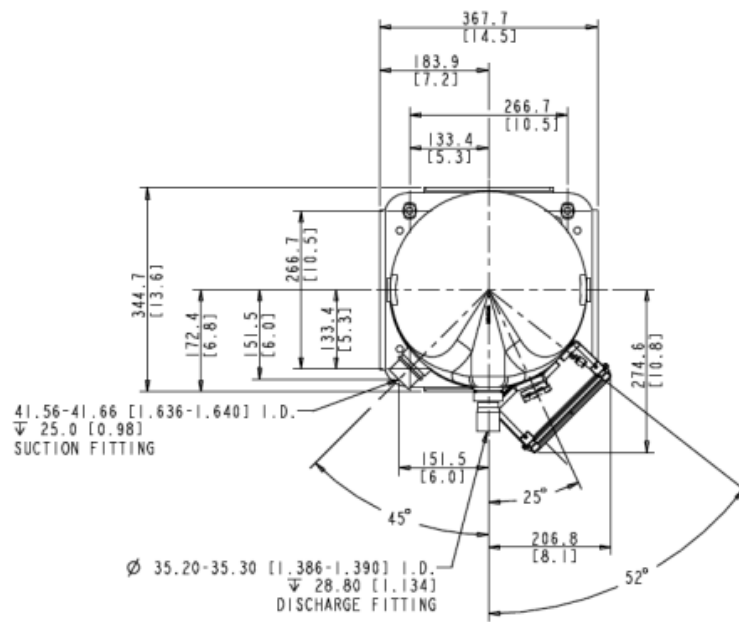

# Model: ZP295KCE-TWD

Image

---

